

**Part Number: 64009-12010**  
**64009-12011**

**Kit Contents**

Item #	Quantity Reqd.	Description
1	1	Package Tray
2	1	Bracket (L)
3	1	Bracket (R)
4	1	Pattern Paper (for $\phi$ 40 hole)
5	1	Pattern Paper (for $\phi$ 6 hole)
6	1	Installation Manual

**Hardware Bag Contents**

Item #	Quantity Reqd.	Description
1	4	Grommet
2	4	Screw
3	2	Bolt
4	2	Nut
5	2	Hanger

**Additional Items Required For Installation**

Item #	Quantity Reqd.	Description

**Conflicts**

Subwoofer Enclosure
---------------------

**Recommended Tools**

<b>Safety Tools</b>	
Vehicle Protection	Blanket/tape, Protective Sheet
Safety Glasses	
<b>Special Tools</b>	
Drill Fixture (LH)	IADS# SXB08-019-01
Drill Fixture (RH)	IADS# SXB08-019-02
Holesaw (40 mm) w/ Centering Pin	IADS# SXB08-019-03
<b>Installation Tools</b>	
Screwdriver	Phillips
Ratchet	
Extension	
Socket	10mm
Wrench	10mm
Drill Bits & Stops	3mm, 6mm
Hand Drill	
Deburring Tool	
<b>Special Chemicals</b>	
Masking Tape	
Packing Tape	
Marking pen	If needed

**General Applicability**

All vehicles.
---------------

**Recommended Sequence of Application**

Item #	Accessory	
1	Quarter Garnish Net	
2	Cargo Net	
3	Package Tray	

\*Mandatory

**Vehicle Service Parts** (may be required for reassembly)

Item #	Quantity Reqd.	Description

**Legend**

 **STOP:** Damage to the vehicle may occur. Do not proceed until process has been complied with.

 **OPERATOR SAFETY:** Use caution to avoid risk of injury.

 **CAUTION:** A process that must be carefully observed in order to reduce the risk of damage to the accessory/vehicle.

 **TOOLS & EQUIPMENT:** Used in Figures calls out the specific tools and equipment recommended for this process.

 **REVISION MARK:** This mark highlights a change in installation with respect to previous issue.

 **SAFETY TORQUE:** This mark indicates that torque is related to safety.

Care must be taken when installing this accessory to ensure damage does not occur to the vehicle. The installation of this accessory should follow approved guidelines to ensure a quality installation.

These guidelines can be found in the "Accessory Installation Practices" document.

This document covers such items as:-

- Vehicle Protection (use of covers and blankets, cleaning chemicals, etc.).
- Safety (eye protection, rechecking torque procedure, etc.).
- Vehicle Disassembly/Reassembly (panel removal, part storage, etc.).
- Electrical Component Disassembly/Reassembly (battery disconnection, connector removal, etc.).

Please see your Toyota dealer for a copy of this document.

### 1. Remove Luggage Board

(a) Open the back door and fold the rear seatback forward.

(b) Disengage the 2 locks and remove the luggage board. (Fig. 1-1)



**NOTE:** Place removed parts on a protected surface.

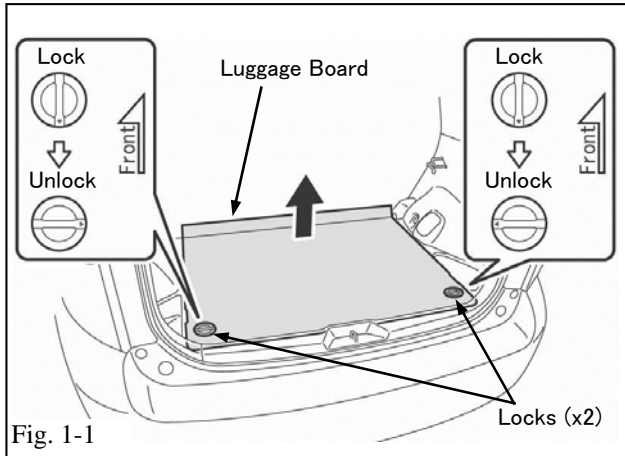

Fig. 1-1

### 2. Remove Luggage Box (Center)

(a) Remove the luggage box (center). (Fig. 2-1)



**NOTE:** Place removed parts on a protected surface.

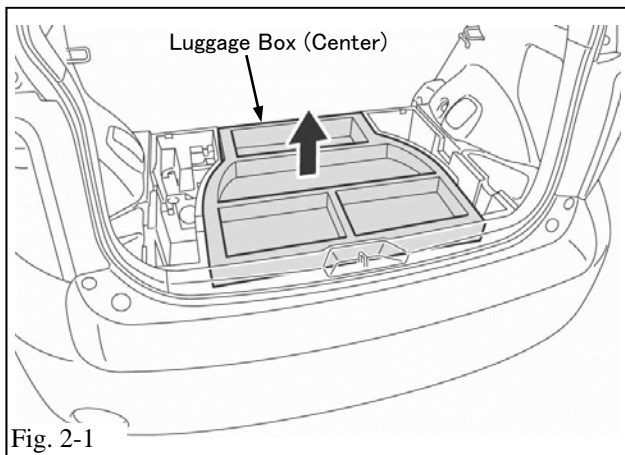
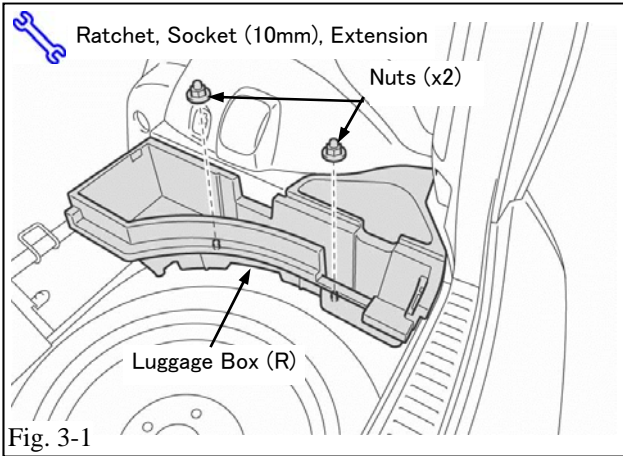

Fig. 2-1



**3. Remove Luggage Box (R)**

- (a) Remove the 2 nuts and remove the luggage box (R). (Fig. 3-1)

**STOP** NOTE: Place removed parts on a protected surface.

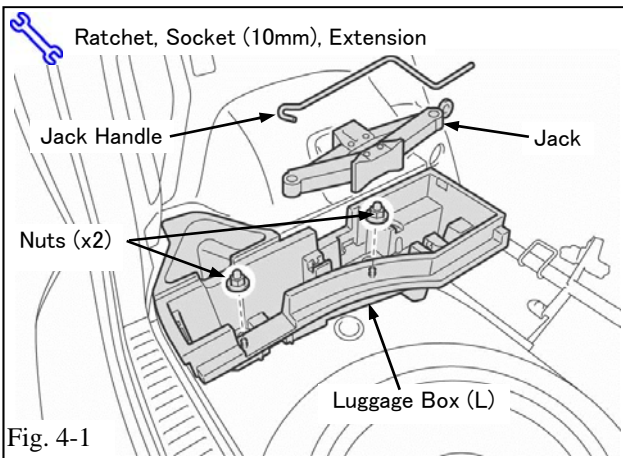

**4. Remove Luggage Box (L)**

- (a) Remove the jack handle and jack. (Fig. 4-1)
- (b) Remove the 2 nuts and remove the luggage box (L). (Fig. 4-1)

**STOP** NOTE: Place removed parts on a protected surface.

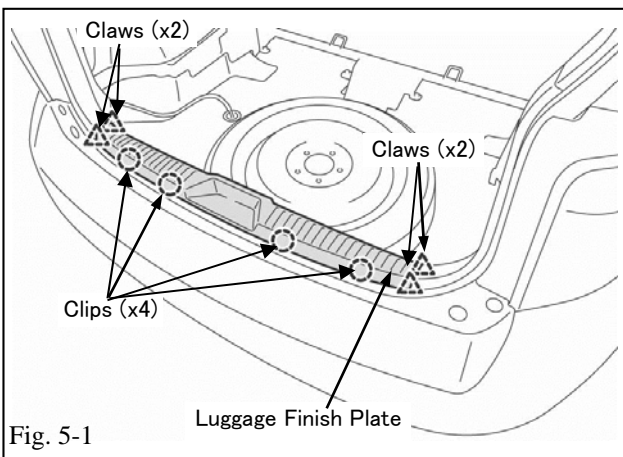

**5. Remove Luggage Finish Plate**

- (a) Disengage the 4 claws and 4 clips and remove the luggage finish plate by pulling up on finish plate. (Fig. 5-1)

**STOP** NOTE: Place removed parts on a protected surface.

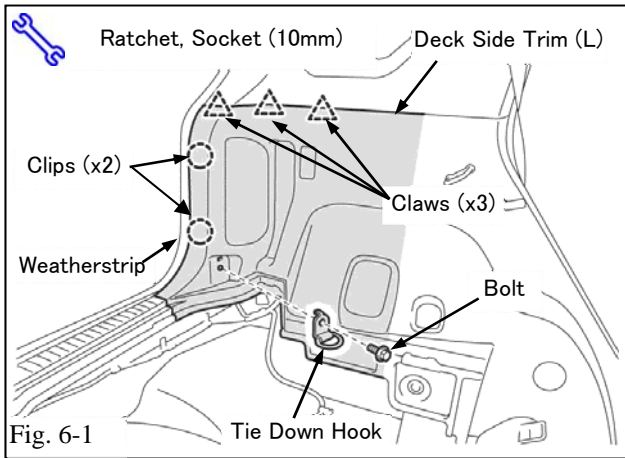

## 6. Drill Deck Side Trim

- (a) Remove the bolt and remove the tie down hook. Also remove the cargo net T-anchor if equipped. (Fig. 6-1)
- (b) Disengage the 2 clips and 3 claws from the deck side trim (L). (Fig. 6-1)



**NOTE:** Place removed parts on a protected surface.

**NOTE:** Do not remove the deck side trim from the vehicle.



**NOTE:** Do not remove the weatherstrip, to prevent the deck side trim from coming loose from the body.

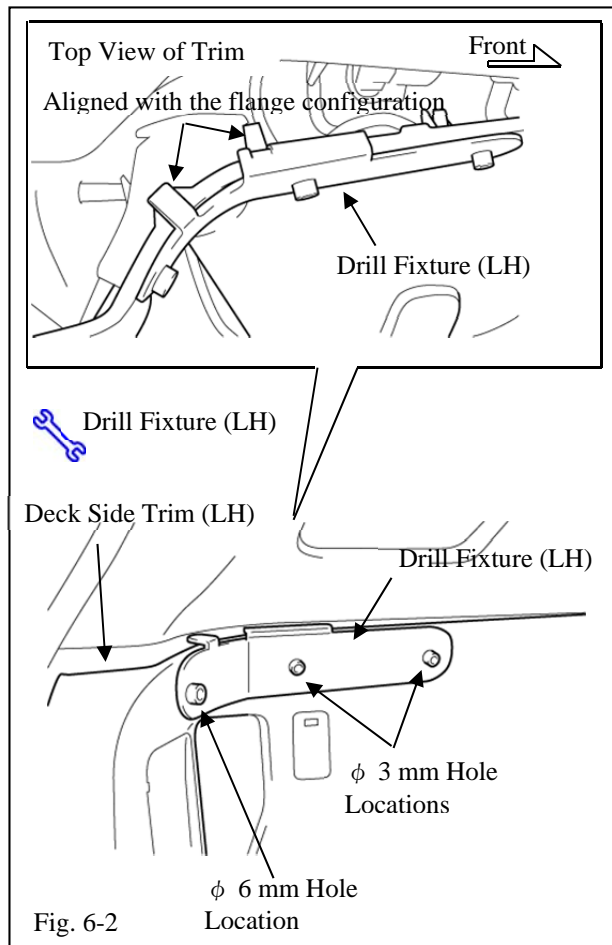

- (c) Partially pull open the deck side trim (L) away from vehicle sheet metal. (Fig. 6-2)

- (d) Align the drill fixture (LH) with the upper flange configuration of the deck side trim (L) and secure it in place, as shown in the illustration. (Fig. 6-2)



**NOTE:** KEEP DECK SIDE trim panel as close to installed position as possible (without engaging clips) during drilling. Panel distortion increases as the deck side trim panel is pulled away from the vehicle sheet metal, causing drill hole misalignment.



**NOTE:** Do not pull the deck side trim out more than necessary, to prevent it from being damaged.

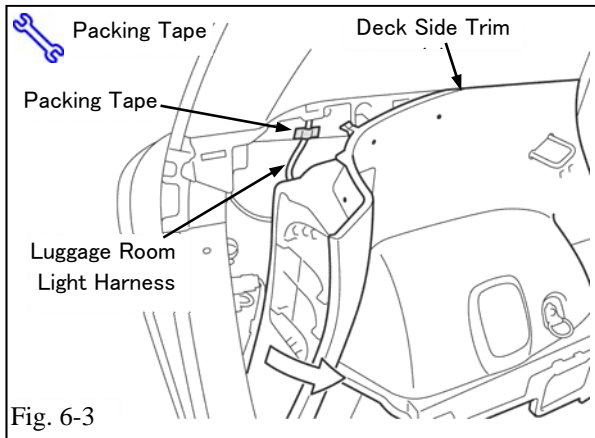

- STOP** (e) Fix the luggage room light harness onto the vehicle sheet metal with a piece of packing tape. Do not overlap the tape over the areas to be drilled. (Fig. 6-3)

**NOTE:** The luggage room light harness is present only on the left side of the vehicle.

- +** Eye protection must be worn during drilling process.

- STOP** (f) Install a drill stopper onto  $\phi 3$  mm electric drill bit as shown in the illustration with the drill fixture secured. If needed, place tape or use marker to indicate 30 mm depth on 40mm on hole saw. (Fig. 6-5a)

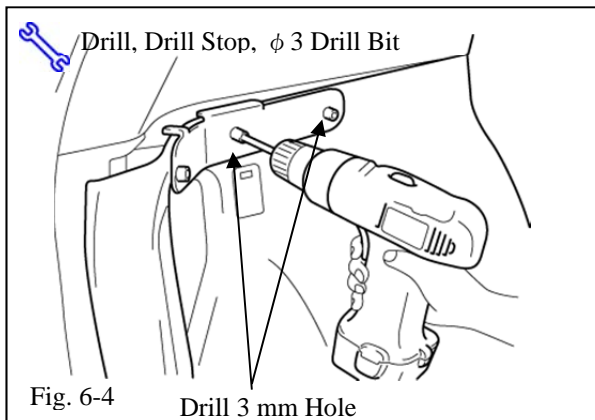

- (g) Open the deck side trim (L) and drill a  $\phi 3$  mm pilot hole in the 2 front hole locations of the drill fixture using the electric drill. (Fig. 6-4)



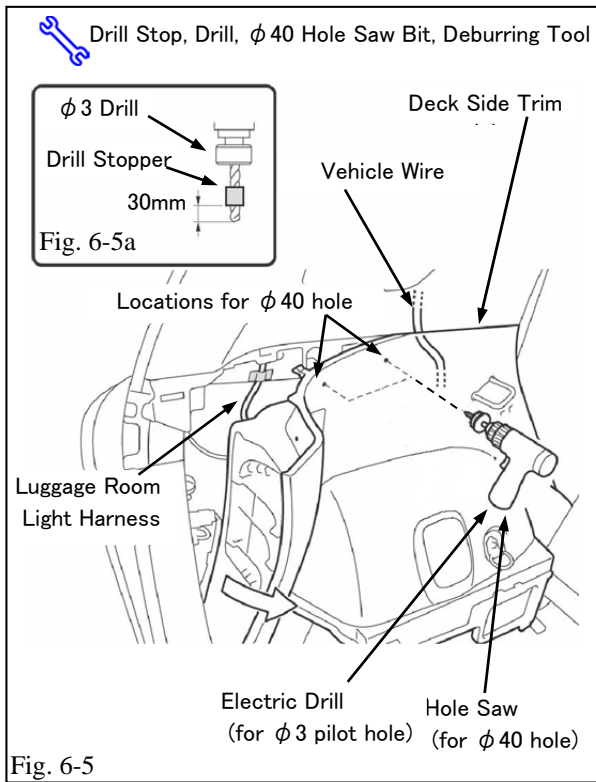

(h) Remove the drill fixture, and then open the deck side trim (L) and drill  $\phi$  40 mm holes in the 2 pilot holes using a hole saw with centering pin. (Fig. 6-5)

**NOTE:** Be sure to keep the fabric material on back side of the trim panel clear of the drilled portions. Do not allow hole saw to drill more than 30 mm deep into panel.

(i) Remove any burrs and chips from the drilled portions and the hole saw bit.

**NOTE:** Do not pull the deck side trim out more than necessary to prevent it from being damaged.

**NOTE:** Operate the electric drill and hole saw with care so as not to damage the vehicle wire harness.

**NOTE:** Hold the electric drill and hole saw perpendicular to the drilling surface.

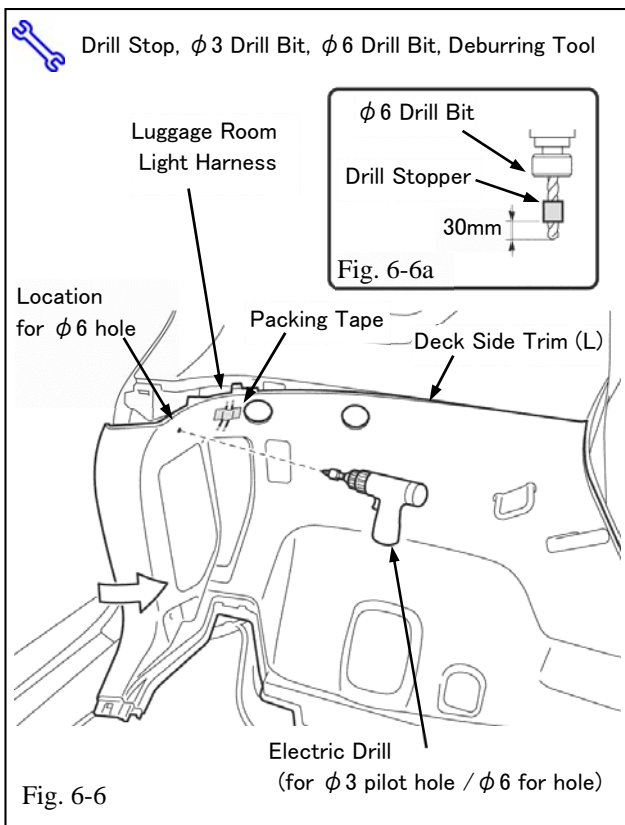

**STOP** (j) Install a drill stopper onto the  $\phi$  6 electric drill bit as shown in the illustration. (Fig. 6-6a)

(k) Reinstall the drill fixture (LH) and secure it in place on the deck side trim (L).

(l) Open the deck side trim (L) and drill a  $\phi$  6 mm hole in the rear most hole location of the drill fixture, using the electric drill. (Fig. 6-6)

(m) Remove any burrs and chips from the drilled portions.

(n) Remove the piece of packing tape securing the luggage room light harness. (Fig. 6-6)

**⚠ NOTE:** The luggage room light harness is provided only on the left side of the vehicle.

**⚠ NOTE:** Do not open the deck side trim more than necessary to prevent it from being damaged.

**⚠ NOTE:** Operate the electric drill with care so as not to damage the luggage room light harness.

**⚠ NOTE:** Hold the electric drill perpendicular to the drilling surface.

(o) Repeat Steps 6(a)-6(n) for RH side.

(p) Clean up the vehicle's interior rear area.

## 7. Install Bracket

(a) Install the 2 grommets into the 2 holes in the vehicle sheet metal as shown in the illustration. (Fig. 7-1)

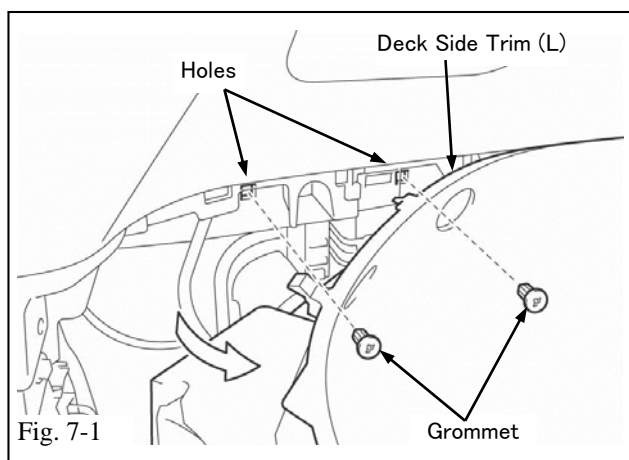
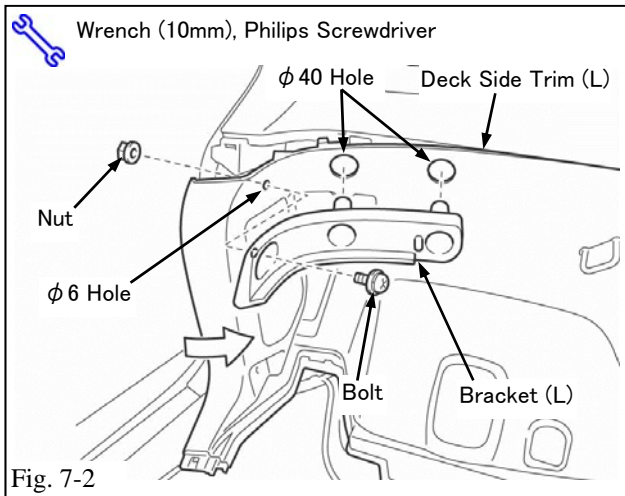
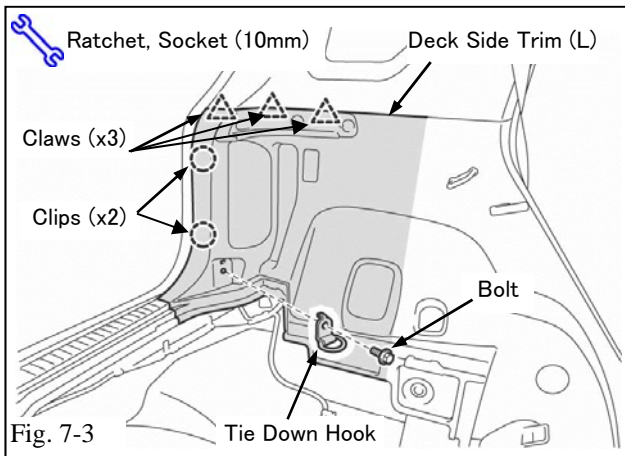

Fig. 7-1



(b) Install the bracket (L) onto the deck side trim (L) with the bolt and nut. (Fig. 7-2)



(c) Engage the 2 clips and 3 claws to reinstall the deck side trim (L). (Fig. 7-3)

(d) Reinstall the tie down hook with the bolt, and the cargo net T-anchor if equipped. Ensure bolts are tight. (Fig. 7-3)

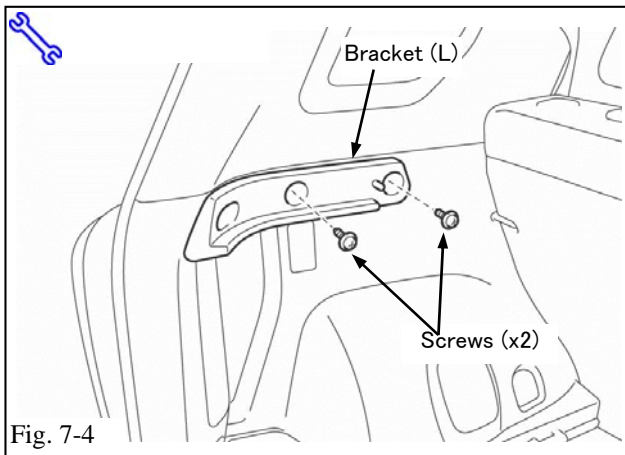

(e) Install the bracket (L) onto the deck side trim (L) with the 2 screws. (Fig. 7-4)

(f) Use the same procedure for the RH side bracket.



### 8. Install Hanger

- (a) Fit the 2 hangers into the cutouts on the door panel. (Fig. 8-1)



**NOTE:** Be careful not to scratch, nick, or cut the rear window defroster wires when installing hangers.

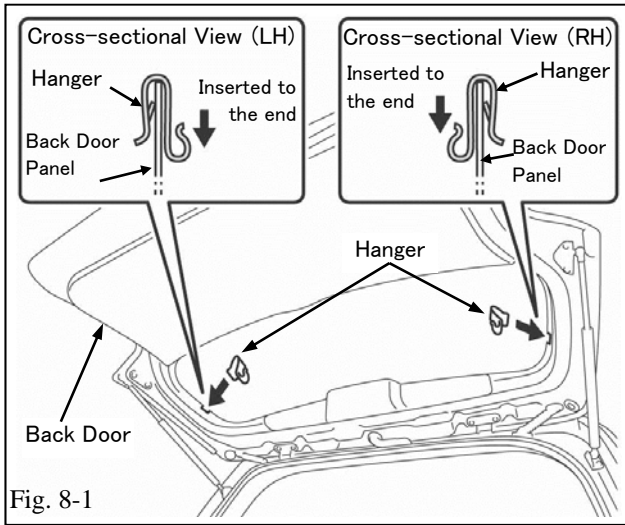

### 9. Install Package Tray

- (a) Fit the recesses in the package tray into the protrusions on the brackets (R and L). (Fig. 9-1)

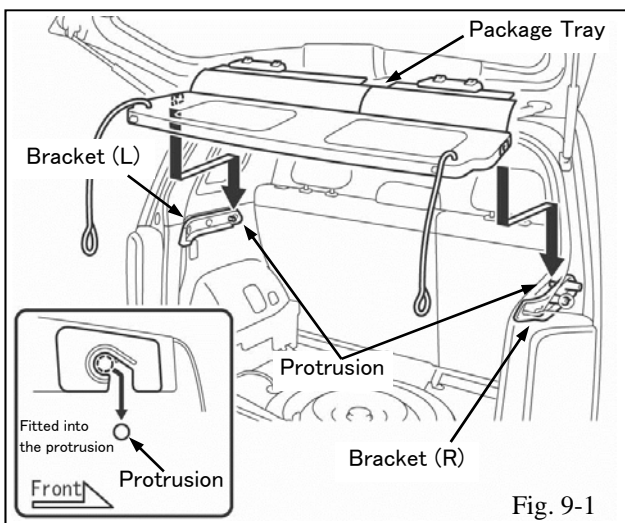

- (b) Pull the headrests up from the rear seats and fit the 4 hooks onto the headrest stays. (Fig. 9-2)

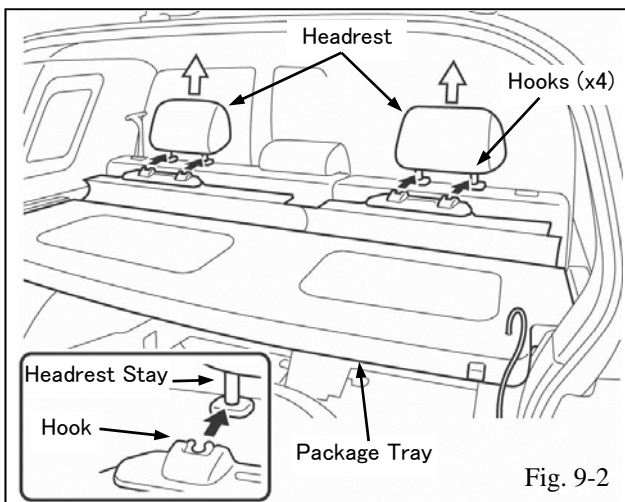

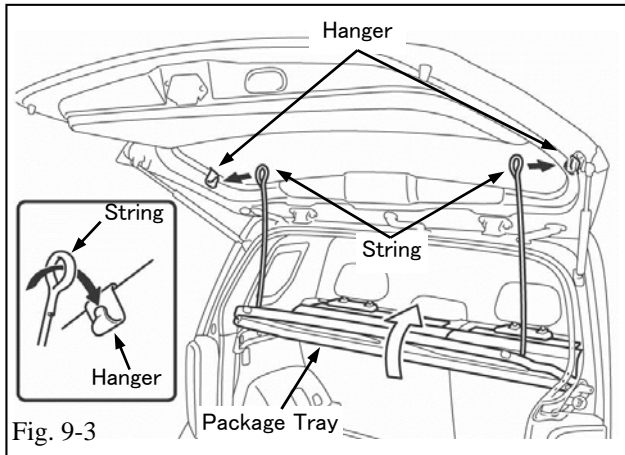

Fig. 9-3

- (c) Hook the 2 pieces of string from the package tray to the 2 hangers. (Fig. 9-3)

### 10. Parts Reinstallation

- (a) Reinstall all parts removed in Steps 1 – 5.
- (b) Ensure the proper fit of all trim panels removed during the installation.

Checklist - these points **MUST** be checked to ensure a quality installation.

Check:	Look For:
<p><u>Accessory Function Checks</u></p> <p><input type="checkbox"/> R and L bracket installation</p> <p><input type="checkbox"/> Package Tray function</p> <p><input type="checkbox"/></p>	<p>Ensure that the screws and bolts are securely tightened</p> <p>Tray lifts smoothly when rear door opens Tray seats properly when rear door closes</p>
<p><u>Vehicle Function Checks</u></p> <p><input type="checkbox"/> Open and close the back door</p> <p><input type="checkbox"/> Inspect vehicle for debris</p> <p><input type="checkbox"/></p>	<p>Ensure that the door opens and closes smoothly</p> <p>Debris in the vehicle</p>
<p><u>Vehicle Appearance Check</u> After accessory installation and removal of protective cover(s), perform a visual inspection.</p>	<p>Ensure no damage (including scuffs and scratches) was caused during the installation process. (For PPO installations, refer to TMS Accessory Quality Shipping Standard.)</p>